

HARKEN®

Single Line Mainsail Reefing System

I N S T R U C T I O N M A N U A L

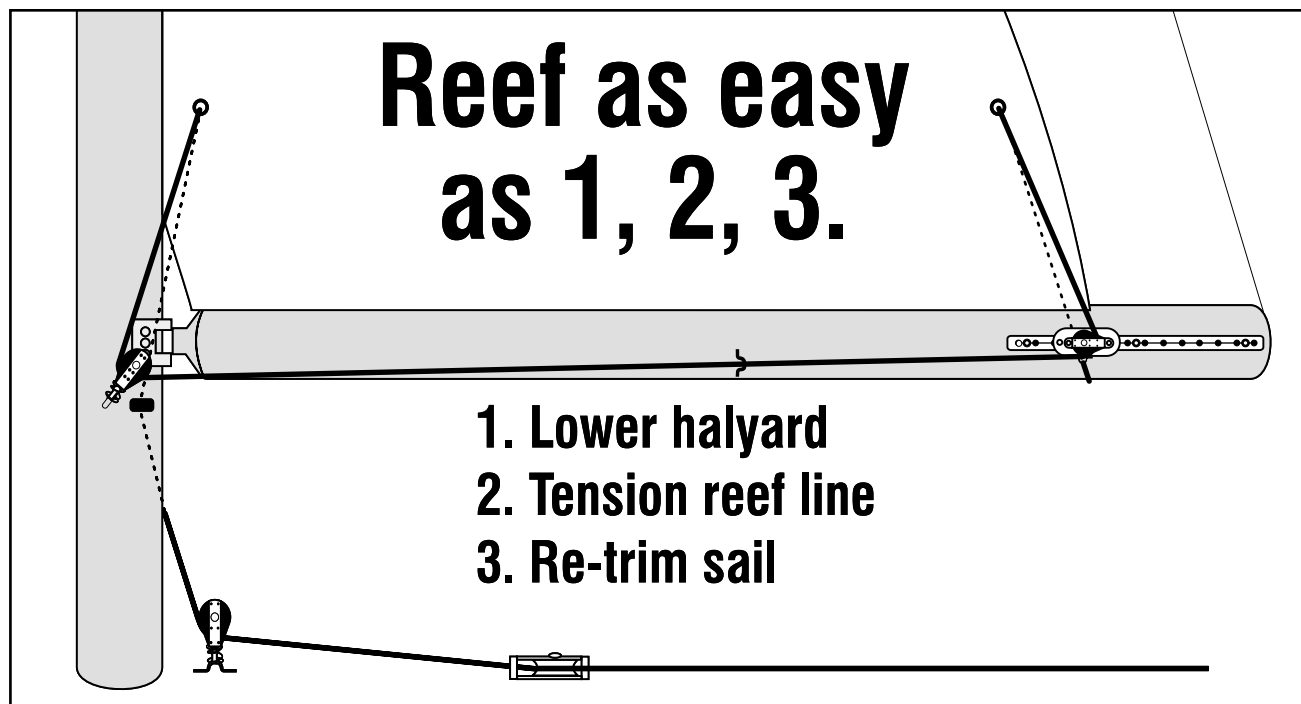

Part #430

For boats 22 - 27 ft. (6-8 m) with mainsail area under 150 ft² (14 m²)

Reef Mainsail with One Line

Easy to Install

Reef From Cockpit in Seconds

Use with Regular or Full-Length Battens

Track Allows Easy Adjustment of Block for Best Sail Shape

No Modification to Sails with Reef Points

Parts (Included)

Clew Track Assembly

- 1 HSB60 Clew Slider Assembly
- 1 H-24294C Track
- 1 833 Blue Loctite® (Threadlocker 242)
 - 6 HFS566 5/16-18 x 3/4" Flathead Screws (1 Extra)
 - 6 HFS841 M8 x 1.25 x 20 mm Flathead Screws (1 Extra)

Mid-Boom Fairlead

- 1 137 Eyestrapp
 - 3 HFS104 #10-32 x 3/8" Trusshead Screws (1 Extra)
 - 3 HFS842 M5 x .80 x 10 mm Panhead Screws (1 Extra)
 - 3 HFS125 #10 x 3/8" Self-Tapping Panhead Screws (1 Extra)

Mast Mounted Tack Block Assembly

- 1 168 Big Bullet Block/071 Spring/137 Eyestrapp
 - 2 HFS104 10-32 x 3/8" Trusshead Screws
 - 2 HFS842 M5 x .80 x 10 mm Panhead Screws
 - 2 HFS125 #10 X 3/8" Self-Tapping Panhead Screws

Mast Mounted Bullseye

- 1 H-24675A Bullseye
 - 3 HFS259 10-32 x 1 1/4" Roundhead Screws (1 Extra)
 - 3 HFS843 M5 x .80 x 30 mm Panhead Screws (1 Extra)
 - 3 HFS840 #10 x 1 1/4" Self-Tapping Screws (1 Extra)

Deck Blocks

- 1 132 Big Bullet Cheek Block
- 1 168 Big Bullet Block/071 Spring/137 Eyestrapp
 - 5 HFS106 10-32 x 1-1/2" Roundhead Screws (1 Extra)
 - 5 HFS110 10-32 18-8 Nuts (1 Extra)
 - 5 HFS111 Washer (1 Extra)
 - 5 HFS112 Lockwasher (1 Extra)

Tools You Must Supply

- Electric Drill
- Drill Bits
- Screwdrivers
 - Slotted
 - Phillips
- Wrench – 3/8" (9.5 mm) or Adjustable
- Hammer
- Center Punch
- Pencil or Fine Point Marker

Drill/Tap Sets You Must Supply

US Drill Bits

- 5/32" for 10-32 Tap Set and for Self-Tapping #10 Screws
- 13/64" for Deck Clearance Holes for #10 Screws*
- 17/64" for 5/16-18 Tap Set

**Used for mounting mast base block to deck, not used if shackling to mast collar. Also used for deflector block, not used if using deck organizer.*

US Tap Sets

- 10-32 optional - you can also use self-tapping screws
- 5/16-18 required for mounting track

Metric Drill Bits

- 4 mm for 10-32 Self-Tapping Screws
- 5 mm for Deck Clearance Holes for #10 Screws*
- 4.2 mm for 5 x .80 mm Tap Set (Optional)
- 6.8 mm for 8 x 1.25 mm Tap Set

**Used for mounting mast base block to deck, not used if shackling to mast collar. Also used for deflector block, not used if using deck organizer.*

Metric Tap Sets

- 5 x .80 mm Optional-you can also use self-tapping screws
- 8 x 1.25 mm Required for mounting track

Parts You Must Supply

- Reefing line – 5/16" (8mm) double braided Dacron line. Use formula below to calculate length.
- Cleat or stopper to secure reefing line.
- High quality marine sealant for mounting deck hardware.
- Back-up plate or large diameter washers for backing up deck hardware screws.
- Topping lift.
- For most effective reefing, the main halyard should be led back to the cockpit.
- Feeder cover plates for grooved spar so sail slugs can pass mast feeder gap. See the bottom of page 7.

Figuring Line Length

- 1 Reef height X 5
- 2 Sail foot length X 2
- 3 Add 7 feet (2.2 m)+ 7 feet (2.2 m)
- Total length of reefing line**

Sail Work

In most cases your mainsail needs no alteration. Check to make sure your sail is fitted with tack and clew reef grommets. Intermediate reef points are used as required.

Step 1 Mounting Track on Boom

General Instructions

A. Decide whether to place the system on the port or starboard side of the boom.

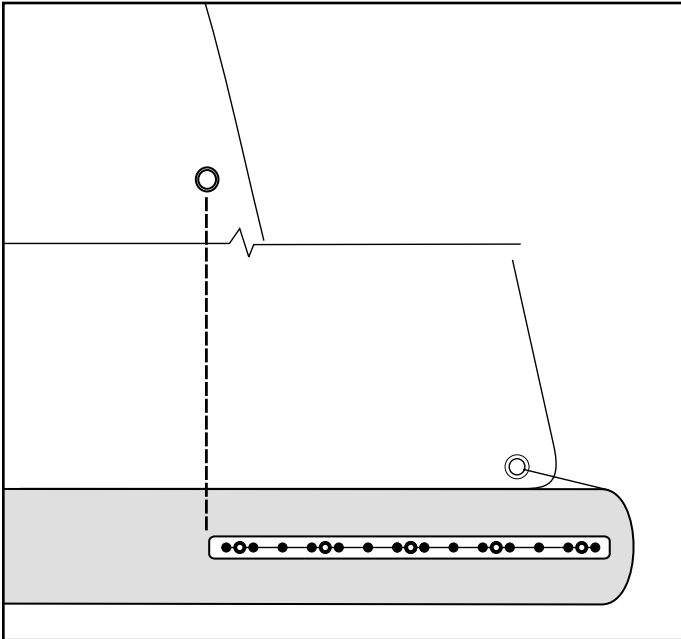

B. Mount track at the aft end of the boom.

Detailed Instructions

A. Each boat is different. Choose the best side by determining if you have room on the boom and where the line will lead on the cabin house. Remember, the line runs down the opposite side of the mast as the track is mounted to the boom. If the track is on starboard, the line will run down the port side of the cabin top. You will need 19" (483 mm) on the aft end of the boom to mount the track.

Installation Tip – Plan the Location of All Hardware Before Installation

Look at the mast area to see if the tack block and bullseye will fit easily. Look at the mast base area. Is there a good spot for mounting the mast base block? Where is the main halyard cleat? If possible, locate the single line cleat near the halyard cleat in easy reach of the cockpit.

B. Place the track so the front edge is behind the aft mainsail reefing grommet. If the boom is not long enough for this, position the track as far aft as possible.

Carefully mark the holes, drill, tap and mount track. See tips below.

	US	Metric
Drill	17/64"	6.8 mm
Tap	5/16-18	8 x 1.25 mm
5 Screws	5/16 -18 x 3/4" Flathead Machine Screws (Use Blue Loctite on Screws)	8 x 1.25 x 20 mm Flathead Machine Screws (Use Blue Loctite on Screws)

Installation Tip – Lining Up Holes with Track

If holes in boom do not line up with track holes, it will be very difficult to install screws. After marking each hole, drill and tap the forward hole and use a screw to secure the track. Use a center punch to start the other holes. If any dimples do not line up, relocate them before drilling holes. Loosen screw and let track pivot out of the way and drill the other holes. **Do not drill holes through track; remove track before drilling.**

Installation Tip – Drilling

Hold the drill perpendicular to the face of the boom. Do not angle the drill or it will be very difficult to install the screws flush with the track.

Step 2 Mounting Clew Slider

General Instructions

A. Install the clew slider on the track, so it's aft of the reef outhaul grommet.

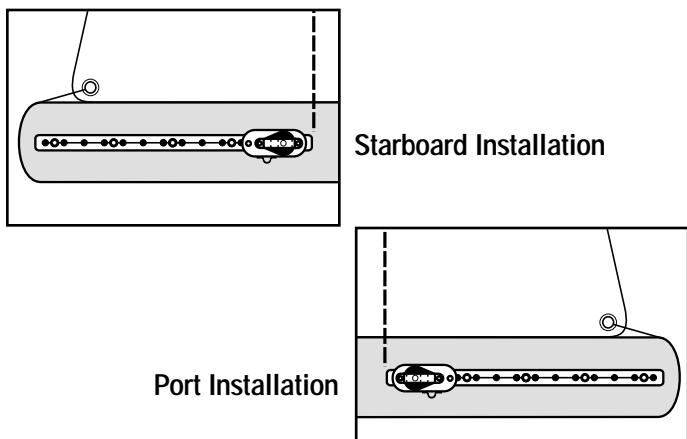

Port-Side Installation

If installing on port side, flip block around.

Step 3 Installing Tack Block

General Instructions

A. Mount the reefing tack block to the mast on the same side as the track is mounted to the boom. Position the block so the line pulls down and forward at 45° when reefed.

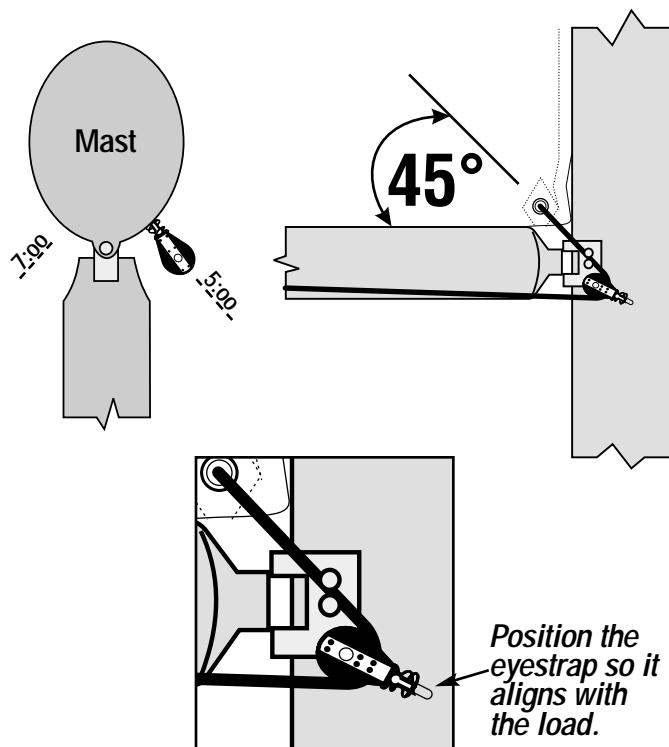

Detailed Instructions

A. Load the clew slider on the track so the eyestrap is down. Secure by tightening the set screw into a positioning hole. This may be adjusted later while adjusting the system at the dock with the sail hoisted.

Port-Side Installation

The car is shipped ready for installation on the starboard side. If installing on the port side of the boom remove the cheek block and reinstall so sheave faces forward.

Detailed Instructions

A. Choose the same side as the track is mounted to the boom. Position the reefing tack block so it's aft of the side of the mast. Looking down from above it will be pointed to 5:00 or 7:00 o'clock depending whether it's mounted on the starboard or port side respectively. Looking from the side, the top of the block should be just below the level of the bottom of the boom. Position the eyestrap, parallel to the load (see diagram).

Self-Tapping		
	US	Metric
Drill	5/32"	4 mm
2 Screws	#10 x 3/8" Roundhead Self-Tapping Screws (Use Blue Loctite on Screws)	
Drilling and Tapping		
	US	Metric
Drill	5/32"	4.2 mm
Tap	10-32	5 x .80 mm
2 Screws	10-32 x 3/8" Roundhead Machine Screws (Use Blue Loctite on Screws)	5 x .80 x 10 mm Trusshead Machine Screws (Use Blue Loctite on Screws)

Installation Tip – Internal Halyards

To keep screw from snagging internal halyards, first install, then remove, nip off the end and reinstall.

Step 4: Installing Tack Bullseye

General Instructions

A. Mount the reefing tack bullseye so it is on the opposite side from the tack block. Position the bullseye so the line pulls down and forward at 45° when reefed.

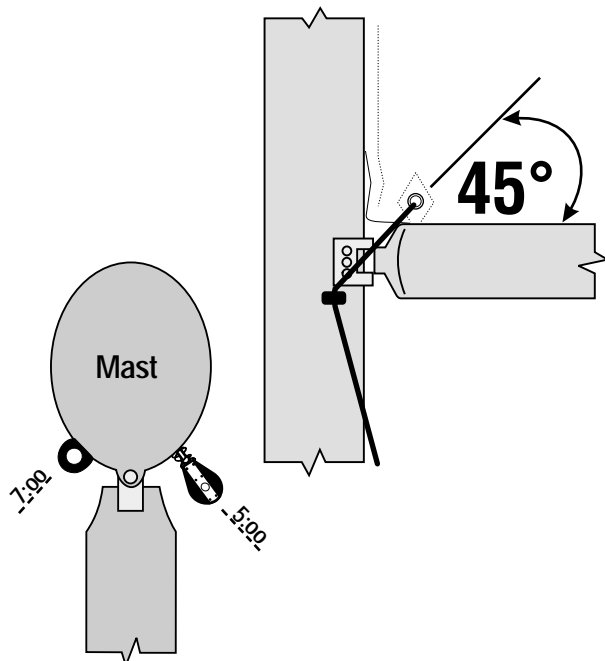

Step 5 Installing Mid-Boom Fairlead Eyestraps

General Instructions

A. Install the eyestraps half way between the clew slider and the mast.

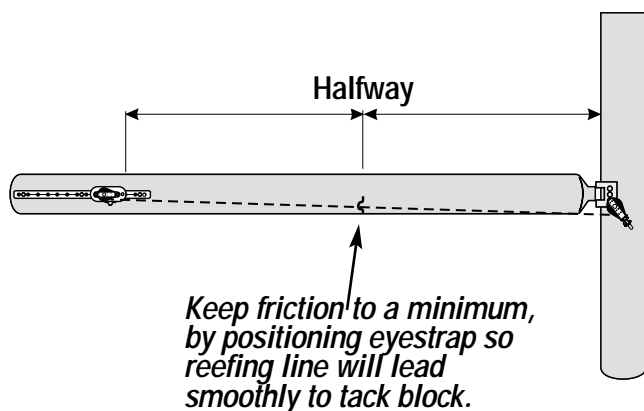

Detailed Instructions

A. Position the reefing tack bullseye so it is on the opposite side from the tack block. Looking down from above it will be pointed to 7:00 or 5:00 o'clock depending whether it's mounted on the port or starboard side respectively. Looking from the side, the bullseye should be just below the level of the bottom of the boom. Position the bullseye so the mounting holes run side to side.

Self-Tapping		
	US	Metric
Drill	5/32"	4 mm
2 Screws	#10 x 1-1/4" Roundhead Screws (Use Blue Loctite on Screws)	
Drilling and Tapping		
	US	Metric
Drill	5/32"	4.2 mm
Tap	10-32	5 x .80 mm
2 Screws	10-32 x 1-1/4" Roundhead Screws (Use Blue Loctite on Screws)	5 x .80 x 30 mm Trusshead Machine Screws (Use Blue Loctite on Screws)

Installation Tip – Internal Halyards

To keep screw from snagging internal halyards, first install, then remove, nip off the end and reinstall.

Detailed Instructions

A. The eyestraps is used to help hold the reefing line from drooping when it is not tensioned. Position the eyestraps so the reefing line runs directly through the eyestraps as it runs from the clew slider to the mast. Choose one of the mounting methods below and install.

Self-Tapping		
	US	Metric
Drill	5/32"	4 mm
2 Screws	#10 x 3/8" Roundhead Self-Tapping Screws (Use Blue Loctite on Screws)	
Drilling and Tapping		
	US	Metric
Drill	5/32"	4.2 mm
Tap	10-32	5 x .80 mm
2 Screws	10-32 x 3/8" Roundhead Machine Screws (Use Blue Loctite on Screws)	5 x .80 x 10 mm Trusshead Machine Screws (Use Blue Loctite on Screws)

Installation Tip – Internal Halyards

To keep screw from snagging internal halyards, first install, then remove, nip off the end and reinstall.

Step 6 Installing Deck Hardware

General Instructions

A. Mount mast base block directly below the bullseye and position so block is angled towards the deflector block or deck organizer.

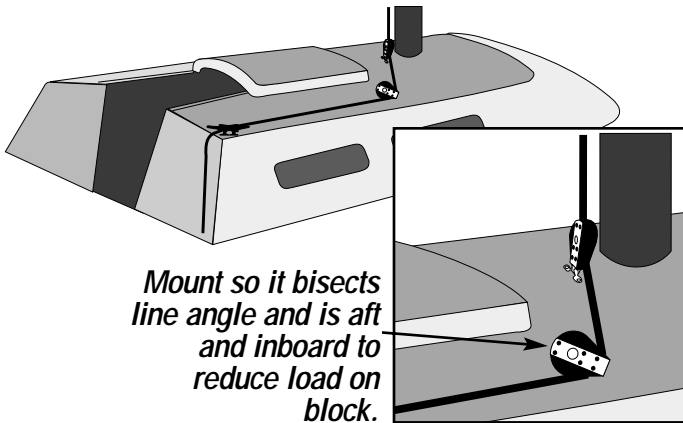

Beveling Top Edge of Hole

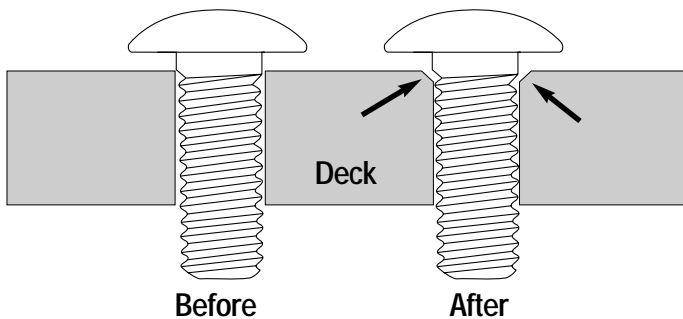

B. Install deflector block so line runs in fore/aft direction to cleat.

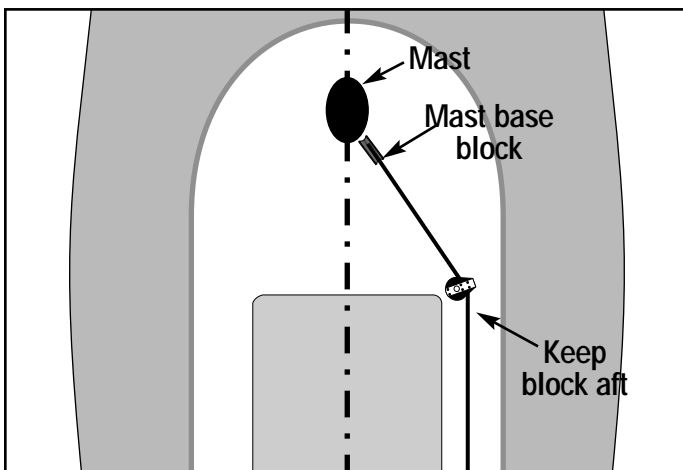

C. Install cleat or line stopper at a convenient spot on the cabin top near the main halyard cleat.

Detailed Instructions

A. If there is a mast collar, remove the eyestraps and shackle the block to the collar. Alternatively, install the block with eyestraps to the deck. Position the eyestraps on the deck below the bullseye. Align the legs of the eyestraps so they are in line with the line direction to the deflector block or deck organizer. Consider the location of the back-up nuts below deck when planning the block's location of the mast base block. See tip below. Drill holes and apply a high quality marine sealant to the holes. See tip below. Install the block assembly. Use a back-up plate or large diameter washers inside the cabin top to back up the hardware.

Drill size - 13/64" (5mm)

Mounting Hardware

- 2 10-32 X 1 1/2" Roundhead screws
- 2 Washers
- 2 Lockwashers
- 2 10-32 Nuts

Marine Sealant – Use to seal holes - See tip below.

Installation Tip – Planning Location of Deck Hardware

It is important to plan the location of all deck hardware before mounting the mastbase block, deflector block and cleat. The position of one block depends on the location of the other block or cleat. In addition, you must consider the location and accessibility of back up hardware inside the cabin top.

Installation Tip – Beveling Top Edge of Hole

After drilling through deck, slightly round off the top edge of the holes with a small knife. This way, when the sealant is applied, it will mass around the screw providing a good durable water seal.

B. The deflector block is used to turn the reefing line so it does not interfere with the companionway hatch or other obstructions on the cabin top:

- 1) Place so line runs in straight fore/aft direction to cleat.
- 2) Keep block aft and inboard to reduce load.
- 3) Check for suitable position for back-up nut and washers.
- 4) Rotate so it bisects line angle.

Drill holes, apply marine sealant and install using:

Drill size - 13/64" (5mm)

Mounting Hardware

- 2 10-32 X 1 1/2" Roundhead screws
- 2 Washers
- 2 Lockwashers
- 2 10-32 Nuts

Marine sealant – Use to seal holes.

C. You will need to supply a cleat or line stopper for the Single Line Reefing system and hardware to mount it. Mount the cleat in a convenient spot within easy reach of the cockpit, near the main halyard cleat if possible. Make sure the cleat or line stopper is through-bolted and has a suitable back-up plate or washers.

Step 7 Reeving the Control Line

General Instructions

- A. Hoist the mainsail.
- B. Starting at the eyestay at the clew slider reeve the line through the sail and blocks.

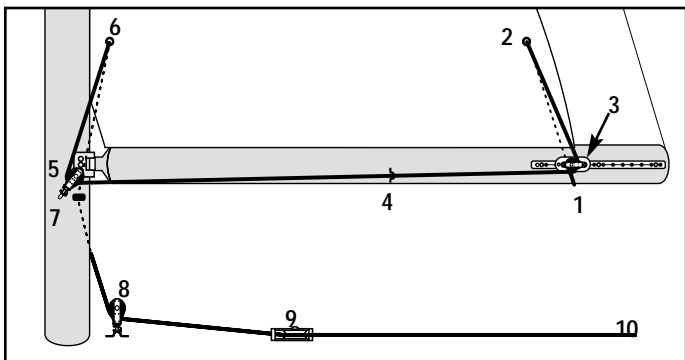

Step 8 Adjust Clew Car

General Instructions

- A. Adjust the clew car to find optimum sail shape. Mark halyard.

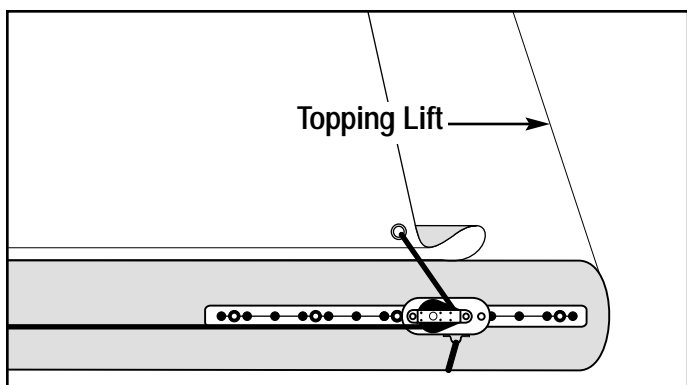

Step 9 Reef

General Instructions

- A. To reef, set the topping lift, ease the halyard, pull the reef line, and tension the halyard if necessary. Test the system before you need to use it.

Detailed Instructions

- B. You need to supply 5/16" (8 mm) double braided Dacron line in a length as determined in the formula on page 2:

- 1) Tie or splice line end to eyestay on clew slider.
- 2) With sail hoisted, run line under the boom and up through reefing grommet at clew.
- 3) Lead down through the block on clew slider.
- 4) Run line forward through eyestay on boom.
- 5) Lead line up through big bullet block on mast.
- 6) Then up through the reefing tack grommet.
- 7) Down through bullseye on other side of mast.
- 8) Through the mast base big bullet block.
- 9) Through deflector block.
- 10) Back to cleat.

Detailed Instructions

- A. With the sail raised, move the clew slider to find the optimum sail shape. Try reefing the system. The clew line should pull down and aft at a 30 to 45° angle. It is important to have a topping lift when reefing to prevent the boom from dropping down into the boat when the halyard is eased.

Reefing Tip – Marking the Halyard

Mark the halyard so you know how far to ease it when lowering the main in preparation for reefing. Start with the sail reefed and the halyard tensioned. Mark the halyard at the cleat using a permanent marker. When reefing the sail, set the topping lift, lower the halyard to the mark and pull the reef line, and tension the halyard if necessary.

Detailed Instructions

- A. Make sure the topping lift is set. Ease the halyard to the mark that you have made and cleat it. Pull the reef line until the clew and tack are down near the boom. Keep pulling until the foot of the sail is tight and cleat the reefing line. Check to make sure you can lower slugs far enough to reef. Do not use stop above feeder gap. Mount feeder plates so slugs pass below feeder. Feeder plates are available from spar makers and are screwed into the mast on either side of the feeder.

HARKEN®

1251 E. Wisconsin Avenue
Pewaukee, Wisconsin 53072 USA
Tel: (262) 691-3320 • Fax: (262) 691-3008
Email: harken@harken.com • Web: www.harken.com; www.harkenstore.com

ZA. Port des Minimes
11 Place du Petit Hunier
17000 La Rochelle, France
Tel: (33) 05.46.44.51.20 • Fax: (33) 05.46.44.25.70
Email: harken@harken.fr

Via Della Cerca 12/14
22070 Lurago Marinone, Como, Italy
Tel: (39) 031.3523511 • Fax: (39) 031.3520031
Email: italy@harken.it