

RECOMMENDATIONS/FINDINGS

This being the second survey I have done in the past four yrs. I have found "CHIP AHOY" IN MUCH BETTER CONDITION THEN MY PREVIOUS SURVEY.THE SCOPE OF IMPROVEMENTS AND THE FUNDS THAT HAVE BEEN SPENT ON HER CARE AND MAINTENCE HAS BEEN INTENSE. SHE IS BETTER EQUIPTED THEN MOST VESSELS SAILING LOCALLY.I FEEL WITH HER MANY,MANY IMPROVEMENTS,IT IS EXTREMELY DIFFICULT TO FIND ANY RECOMMENDATIONS FOR HER OWNER. THE REPLACEMENT COST FOR "CHIP AHOY',NOW IS SOMEWHERE AROUND \$35,000. A NEW VESSEL OF HER SIZE FROM CATALINA WOULD BE CLOSE TO 35,000,PLUS ALL THE EQUIPMENT ABOARD HER,A NEW OWNER WOULD BE SPENDING CLOSE TO \$50,000.

I FEEL SHE IS VERY GOOD INSURANCE RISK AND SHOULD BE INSURED FOR \$25,000,TO PROTECT THE INVESTMENT THE OWNER HAS PUT FORTH.

RECOMMENDATIONS/FINDINGS WERE DISCUSSED WITH THE OWNER/MASTER OF THE VESSEL.THIS SURVEY HAS BEEN PREPARED AND SUBMITTED IN GOOD FAITH.IT IS UNDERSTOOD AND AGREED THAT THE SERVICES RENDERED BY CAPT. ALLAN JAY WALDMAN NAVTECH CERTIFIED MARINE SURVEYOR AS THE ATTENDING SURVEYOR WERE PREFORMED TO THE BEST OF MY ABILITIES.ANY REPORTS FURNISHED,EITHER ORAL OR IN WRITING,ARE ACCEPTED AS MY OPINION AND BEST JUDGEMENT.THEY ARE NOT IN ANYWAY INTENDED AS A REPRESENTATION OR WARRANTY AS TO THE CONDITION OF THE VESSEL OR ANY OF IT'S PARTS. IT IS FURTHER UNDERSTOOD AND AGREED THAT THIS SURVEYOR OF RECORD WILL NOT BE RESPONSIBLE FOR ANY LOSS OR DAMAGE DIRECT OR CONSEQUENCIAL,ARISING OUT OF THE CONDITION OF THE VESSEL,OR ANY ERROR OR OMISSION ON MY BEHALF AS SURVEYOR.

PAYMENT AND OR USE OF THIS SURVEY REPORT CONSTITUTUTES ACCEPTANCE OF THESE CONDITIONS.

Total charges;\$286.00

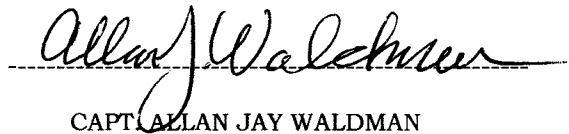

CAPT. ALLAN JAY WALDMAN

CERTIFIED MARINE SURVEYOR

CAPTAIN ALLAN WALDMAN
CERTIFIED NAVTECH MARINE SURVEYOR

13 DRUMLIN RD. MARBLEHEAD, MA.
01945

ATTACHMENTS
PAGE (/) OF (10)

PRIVILEGED AND CONFIDENTIAL

SURVEY REPORT NUMBER: 2

SCOPE OF THIS SURVEY REPORT: THIS IS THE SECOND SURVEY, I AM DOING ON "CHIP AHOY", AFTER FOUR EXTENSIVE YEARS OF RECONDITIONING AND EQUIPMENT UPGRADES, FOR A REVALUATION OF THE VESSEL.

PARTY REQUESTING THIS SURVEY: ROBERT FORD

BUYER:

ADDRESS: 145 VILLAGE ST.

CITY: MARBLEHEAD STATE: MA ZIP: 01945

HOME: OFFICE: CELL: FAX:

UNDERWRITER:

POLICY NO:

NAME OF VESSEL: CHIP AHOY

MODEL YEAR: 1974

DATE OF CERTIFICATION OR MANUFACTURE:

REGISTRATION/DOCUMENTATION NUMBER: SERIAL#CTY032820374

HOME PORT: MARBLEHEAD, MA.

TYPE OF VESSEL: SLOOP

INTENDED USE: PRIVATE

DATE OF SURVEY: 06/12/08

DATE OF THIS REPORT: 06/19/08

SURVEY CONDUCTED AT: VILLAGE ST. MARBLEHEAD, MA.

IN OR OUT OF WATER: OUT

OWNER/BUYER PRESENT AT SURVEY: YES

DESIGNER/BUILDER: BUTTLER, CATALINA

MODEL: C22

BUILDERS HULL NUMBER: CTY032820374

USCG DOCUMENTATION QUERY ATTACHED: NO

BOAT HISTORY REPORT ATTACHED:

HULL MATERIAL: FIBERGLASS

HULL COLOR AND GRAPHICS: RED

LOA: 22'

LOD: 22'

LWL: 19'

BEAM: 8'

DRAFT: 2.5'/BOARD UP 5'/BOARD DOWN

GROSS TONS:

NET TONS: 3

SPEED: 6-7KNTS.

PRESENT MARKET VALUE: \$9,200

REPLACEMENT COST WITH A NEW YACHT: \$35,000

{VG=VERY GOOD} {GVG=GOOD TO VERY GOOD} {G=GOOD} {FG=FAIR TO GOOD} {F=FAIR} {P=POOR}

These key codes reflect the current condition of the vessel with respect to the date of manufacture/build

(* indicates notation in the recommendation/findings pages. (** indicates not on board or not applicable at this time

HULL. FIBERGLASS

BULKHEADS/JOINERWORK/HEADLINER/HULL LINERS: 1/2" TEAK MARINE PLYWOOD,ALL JOINER WORK IS SOLID TEAK,HEADLINER IS SOLID GLASS

DECK: FIBERGLASS/PLYWOOD CORE

BILGES: SHALLOW/VERY CLEAN

STRINGERS/TRANSVERSE FLOOR FRAME/MEMBERS: ALL SOLID GLASS/EXCELLENT CONDITION

FIBERGLASS TABBING/SECONDARY BONDING: ALL BONDING IS EXCELLENT

SHEER CLAMPS/DECK & HULL JOINT: DECK BOLTED TO HULL WITH 1/2" STAINLESS BOLTS

BOW/STERN RAILS: ALL THE STANCHIONS,BOW PULPIT,LIFELINES,AND STERNRAILS HAVE BEEN REPLACED,ALONG WITH NEW STAINLESS BACKING PLATES/EXCELLENT

BOW PULPIT: VG

FITTINGS: ALL STAINLESS

FASTENINGS: ALL STAINLESS/VG

RUB RAILS/TOE RAILS: ALUMINUM/PLASTIC

HATCHES: POPTOP HATCH/WITHNEW POP-TOP POWER LIFT ASSEMBLY/EXCELLENT/NEW FORWARD HATCH INSTALLED

PORTHOLES: 4/FIXED GLASS PORTS

VENTILATION: SOLAR POWERED VENT

BIMINI: NONE

UPHOLSTERY:

TANK AND FUEL LINES

FUEL/TOTAL GALLONS: 12

TANK MATERIAL: PLASTIC

TANK CONDITION: Appearing intact where visible and accessible. Limited, confined and restricted inspection access.

LOCATION OF TANKS: Under the cockpit sole.

FILLER HOSE: USCG type A2 approved; SAE J1527 and piped tight to the filler plate. (GVG).

FUEL LINES: USCG type A1 approved; SAE J1527. (GVG).

FUEL SEPARATORS/FILTERS: Mercury #35-802893T fuel water separator filter. (G).

FUEL SHUT-OFF VALVES:

OVERFLOW: USCG approved; SAE J1527. (GVG).

TANK GROUNDED TO THE DECK FILLER PLATE: Yes

MECHANICAL OR ELECTRICAL FUEL GAUGE: (1) fuel gauge at the helm instrumentation panel. (GVG)

FUEL TANK SECURED: Chocked tight in place where accessible and visible. (GVG).

TANK FACTORY INSTALLED: Yes

FUEL TANK PRESSURE TESTED: No

NOTES:

GALLEY

LOCATION: CABIN

STOVE: ORIGO ALCOHAL STOVE 3000/2 BURNER

INSTALLATION:

LOCATION OF STOVE FUEL: OUTSIDE/COCPIT SEATS

SINK: 0

REFRIGERATOR: 0

STOWAGE:

PIPING:

HOSES:

FRESH WATER SYSTEM:

HOT WATER HEATER:

ICE MAKER:

ADDITIONAL GALLEY EQUIPMENT:

GALLEY/LAUNDRY PARTICULARS:

FIRE EXTINGUISHERS

TYPE/LOCATION/INSPECTION: 3 NEW KIDDIE

FIXED FIRE SYSTEM

MANUFACTURER/MODEL NUMBER:

LOCATION:

SYSTEM TRIGGERED:

INSPECTION DATE:

SHUTDOWN/OVERRIDE:

FLAME/TEMPERATURE ALARM:

CARBON MONOXIDE/CO2 DETECTOR(S):

PERSONAL FLOATATION DEVICES (PFD'S)

TYPE/LOCATION/CONDITION: 6 /OFFSHOR VESTS

LIFE RING: YES

MAN OVERBOARD POLE/MOB: NO

HARNESSES: YES

INFLATABLE RAFT(S): 0

WATER LIGHTS: YES

FLARES: YES

EPIRB(S): YES

FIRST AID KIT: YES

DINGHY DAVITS:

DINGHY/TENDER: YES

MOTOR: 3HP

ADDITIONAL EQUIPMENT:

GROUND TACKLE

ANCHOR WINDLASS: 0

ANCHOR DAVIT: YES

ANCHOR(S): 2

ANCHOR CHAIN/RODE: 400 FT

DOCK/SPRINGLINES: 6

MOORING ARRANGEMENT/LOCATION/SUPERVISION: MOORED IN SALEM HARBOR,1500LB BLOCK

TANKS AND FUEL LINES

FUEL/TOTAL GALLONS: 12
NUMBER OF TANKS: 2
TANK MATERIAL: PLASTIC
TANK CONDITION: VG
LOCATION OF TANKS: UNDER COCPIT

FILLER HOSE(S):
FUEL LINES: 2;TYPEB2,WITH FILTER
FUEL SEPARATORS/FILTERS:
OVERFLOW:

VENTILATION: YES
BLOWERS:

SHUT-OFF VALVES:

TANK(S) GROUNDED TO THE DECK FILLER PLATE:
MECHANICAL OR ELECTRICAL FUEL GAUGE:

FUEL TANK(S) SECURED: YES
TANK(S) FACTORY INSTALLED: NO

FUEL TANK(S) ACCESSIBILITY: VG
FUEL TANK(S) PRESSURE TESTED: YES
FUEL SAMPLE TESTED: NO

LPG TANK(S)

TANK MATERIAL/MANUFACTURER:
LOCATION:
CAPACITY:
REGULATOR:
SOLENOID:
SUPPLY LINES APPROVED:
SHUT-OFF VALVE:
SINGLE STAGE OR TWO STAGE INSTALLATION:
VENTILATION:
CONTROL PANEL SWITCH/SOLENOID TESTED:

POTABLE WATER TANK(S)

NUMBER OF TANKS/TOTAL GALLONS: 1
MATERIAL: PLASTIC
LOCATION: IN CABIN
WATER TANK(S) SECURED: YES
LINES:
PRESSURIZED OR MANUAL SYSTEM: WATER IS CARRIED IN 6GALLON PLASTIC TANK
POTABLE WATER SYSTEM COMMISSIONED:

GRAY WATER / HOLDING TANK (MSD)

NUMBER OF TANKS: 0
MATERIAL: 0
LOCATION: 0
TANK(S) SECURED: 0
DECK PUMP OUT/OVERBOARD DISCHARGE: 0
USCG APPROVED MARINE SANITATION DEVICE: 0

NOTES: PORTA-POTTY

ELECTRICAL SYSTEMS

WIRING: MARINE GRADE

FUSES/BREAKERS: MODEL42210 BREAKER PANEL

BATTERY SELECTOR SWITCH/MASTER SWITCH: COLE HEARSE/3STAGE SWITCH/NEW

MAIN ENGINE BATTERIES: 2 NAUTILUS EXIDE 27/NEW

AUXILIARY BATTERIES:

ELECTROLYTE CELL READINGS: NONE

BATTERY PROTECTION: YES

SHORE POWER ARRANGEMENT: NONE

SHORE POWER CORD(S):

WIRING PROGRAM: ALL NEW WIRING AFTER A LIGHTENING STRIKE

CIRCUIT PROTECTION:

CABIN LIGHTING: 3 OVERHEAD LIGHTS

CONVERTER/CHARGER: CHARGER/ALTERNATOR OFF NEW MOTOR

INVERTER: NONE

POLARITY INDICATOR: NONE

GALVANIC ISOLATOR INSTALLED: NONE

ELECTRICAL SYSTEM DETAILS: ALL WIRING/CONNECTIONS REPLACED/2006

ELECTRONIC EQUIPMENT

VHF RADIO(S): ICOM M302 /NEW VHF ANTENNA,COAX CONNECTORS/BULBS

HANDHELD VHF: uniden voyager

RADAR:

LORAN:

SATNAV: GARMIN GPSMAP76CS/

AUTOPILOT: Raymarine ST 2000/TillerPilot/with Remote

DEPTH SOUNDING DEVICES/INDICATOR(S): HUMMINGBIRD HDR-610/PUCK TRANSDUCER/NEW

SINGLE SIDEBAND:

KNOT LOG: NONE

BAROMETER: WEEM'S and PLATH

SHIP'S CLOCK: NONE

ANEMOMETER: NONE

SHIP'S COMPASS: RITCHIE NAVIGATOR/3BN-202

SEARCH LIGHT: YES

NAVIGATION LIGHTS: MAST WIRING HARNESS/DECK CONECTOR NAV. LIGHTS ANCHOR LIGHTS/NEW

COCKPIT/DECK LIGHTS:

WASHERS/WIPERS:

SHIP'S BELL: YES

SIGNALING DEVICE: HORN

HAILER: YES

ADDITIONAL EQUIPMENT/ELECTRONICS: WINDEX/COMPASS LIGHT/DEPTH GAUGE/ALL NEW

HEATING/AIR CONDITIONING:

RAW WATER CIRCULATING PUMP:

ZINC ANODES & BONDING SYSTEM: HULL IS BONDED TO BOLT IN BILGE

MAIN ENGINE(S)

ENGINE MANUFACTURER: HONDA MODEL:4-STROKE
YEAR: 2006 CYLINDERS: 2 HP: 8
PORT ENGINE SERIAL NUMBER: STARBOARD ENGINE SERIAL NUMBER: 1501171
PORT ENGINE HOURS: STARBOARD ENGINE HOURS: 25
OVERHAUL/REBUILD/MAINTENANCE PROGRAM:

ENGINE CONTROLS: MORSE
ENGINE IGNITION/EMERGENCY KILL SWITCHES: ELECTRIC START/WITH KILL SWITCH/
ENGINE NEUTRAL SAFETY SWITCH OVER RIDE TESTED:
ENGINE INSTRUMENTATION:
ENGINE ALARMS:
ENGINE SYNCHRONIZER:
ENGINE DRIVE BELTS AND PULLEYS:
FLAME ARRESTORS/BREATHERS:
BLOWERS:

EXHAUST SYSTEM:
ENGINE COOLING:
ENGINE COOLANT LEVELS:
THROUGH HULL SEACOCKS:
SEA STRAINERS:

ENGINE STRINGERS/BEDS:
ENGINE MOUNTS:

TRANSMISSION MANUFACTURER: MODEL NUMBER:
PORT TRANSMISSION SERIAL NUMBER: STARBOARD TRANSMISSION SERIAL NUMBER:

LUBE OIL STORAGE/TRANSFER:
ENGINE OIL LEVELS:
OUTDRIVE GEAR OIL MONITOR:
ENGINE OIL FILTERS:
SHAFT MATERIAL/SHAFT ALIGNMENT:
COUPLINGS:
PROPS:
SHAFT STRUTS & CUTLESS BEARINGS:
STUFFING BOXES:
RUDDERS:
RUDDER LOGS:
TRIM TABS:
STEERING SYSTEM:
BOW THRUSTER:

BILGE PUMPS:

GENERATOR

MANUFACTURER: MODEL NUMBER: YEAR:
SERIAL NUMBER: TYPE: HOURS:
CYLINDERS: COOLING:
REBUILT/OVERHAULED:
LOCATION: CONDITION:
GENERATOR OIL AND COOLANT LEVELS:
EXHAUST SYSTEM:
FLAME ARRESTOR/BREATHING:
SOUND/HEAT INSULATED COVER:
RESULTS OF POWER-UP/TESTING:

NOTES:

MAIN ENGINES

ENGINE MANUFACTURER: TOHATSU MODEL: M9.9B YEAR: 1985
ENGINE HOURS: 125 CYLINDERS: 2 HP: 9.9
PORT ENGINE SERIAL NUMBER: 83752
STARBOARD ENGINE SERIAL NUMBER:

OVERHAUL/REBUILD/MAINTENANCE PROGRAM:

OIL INJECTION RESERVOIR(S):
EXHAUST:

ENGINE CONTROLS:
ENGINE INSTRUMENTATION:
ENGINE IGNITION/EMERGENCY KILL SWITCHES:
ENGINE NEUTRAL SAFETY SWITCH OVER RIDE TESTED:

ENGINE ALARMS:

THROUGH HULL SEACOCKS/STRAINERS:

ENGINE STRINGERS/BEDS:

PROPS:

STEERING SYSTEM:

TRIM TABS:

BILGE PUMPS: RULE 270/with Float and Auto Switches

BILGE BLOWER(S):

FIRE EXTINGUISHER(S):

PORT CYLINDER COMPRESSION READINGS

No. 1: No. 2:
No. 3: No. 4:
No. 5: No. 6:

STARBOARD CYLINDER COMPRESSION READINGS

No. 1: No. 2:
No. 3: No. 4:
No. 5: No. 6:

NOTES:

Both engines appear to have been well maintained with very little running time.
Operational readings after full warm-up were very good.
Both engines were shifted in and out of gear.
Both engines idling @ 900-950.
Volts charging on both engines @ 14.0.
Independent temperature readings taken from the power heads @ 143 – 145 degrees.
Oil pressure on both engines very good.

Note the excellent compression testing results from all cylinders on both engines.

The lower unit drain-plugs with integral magnets were pulled. Both lower unit fluids were clean with no metal filings collected on the magnet.

Both outboard service switches tested operational lifting and lowering the engines.

SAIL RIGGING

CRUISE OR RACE EQUIPPED: CRUISING

NUMBER OF MASTS: 1

RIG: SLOOP

KEEL: CENTERBOARD

BALLAST:

MAST AND SPAR MATERIAL: ALUMINUM

MAST MOUNTING: DECK STEPPED

CHAIN PLATES: 1/2" STAINLESS

TURNBUCKLES: STAINLESS

BACKSTAY ADJUSTER: HARKEN/NEW

BOOM VANG: BOOMKIKER/WITH FITTINGS/NEW

MAINSHEET TRAVELER: HARKEN

SPINNAKER POLE:

WHISKER POLE:

ROLLER REEFING SYSTEM: FURLEX 100S

WINCH INVENTORY: 2 NEW LEWMAR 14ST

SAIL INVENTORY: NEW 113210LL-ULMAN OFFSHORE FULL BATTENED MAINSAIL/2007 ANDERSON GENOA/VG

RUNNING RIGGING: ALL RUNNING RIGGING REPLACED/ 2006

STANDING RIGGING: ALL NEW STANDING RIGGING REPLACED/2006

ADDITIONAL EQUIPMENT: MANY NEW BLOCKS REPLACED/2005-2008

SAIL DIMENSIONS

I = 25'
E = 11.6
P = 23.16
J =
IY =
EY =
PY =

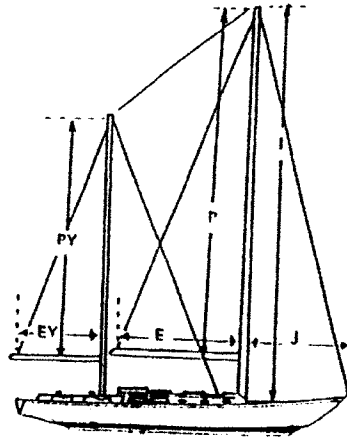

RIGGING NOTES: THE RUNNING AND STANDING RIGGING ON CHIP AHOY IS THAT OF A VESSEL ALMOST TWICE HER SIZE. THE UPGRADES MAKE HER A STONG 22' SAILBOAT, FOR WINDS UP TO 40MPH.

ADDITIONAL GEAR/EQUIPMENT AND APPURTENANCES

1. NEW HONDA 4-STROKE 8 HP
2. SCREENS FOR HATCHES
3. STAINLESS STEEL FLAG MOUNT
4. DAVIS ECHOMASTER RADAR REFLECTOR
5. HARKEN ROPE CLUTCHES
6. MOTOR MOUNTING BRACKET
7. DEPTH GAUGE
8. C22 UNIFOIL HIGH PERFORMANCE KICK UP RUDDER
9. KEEL CABLE ASSEMBLY
10. BOOMKICKER
11. NEW FORWARD HATCH AND STAINLESS HARDWARE
12. ICOM302 VHF RADIO AND CABLE PLUS CONNECTORS
13. DELTA FAST SET ANCHOR/14LBS
14. TILLER PILOT ST 2000
15. WEEMS&PLATH ATLANTIC OIL LAMP
16. ALL NEW REEFING LINES AND BLOCKS
17. LAZY JACKS
18. TRAILER; TOTALLY REFURBISHED; BEARINGS TONGUE JACK , TIRES
19. LIFE RING AND BRACKET
20. ANCHOR RODE AND CHAIN
21. FENDERS
22. HUMMINGBIRD HDR 610 DEPTH FINDER
23. MAIN HALYARD
24. CABIN CURTAINS
25. BATTERY BOXES AND CABLES / WITH NEW BATTERIES
26. 2ND. ANCHOR / 200FT OF LINE
27. BATTERY SWITCH
28. CENTERBOARD SYTEM / OVERHAULED TWICE
29. NUMEROUS OTHER FITTINGS GEAR REPAIRS
30. 3-NEW FIRE EXTINGUISHERS
31. 2-SOSPENDERS PERSONAL LIFE VEST
32. ORION FLARE KIT / DATE 2009
33. DINGHY; ONE BEACON BOAT MODEL LYNX 9' SERIAL #BEBL9268D101 / MOTOR JOHNSON 3HP.
34. TYPE: 3 STEARNS SAR VEST
35. WEST MARINE ULTIMATE SAFETY HARNESS
36. ACR FIREFLY 3 STROBE LIGHT / ACR733 STROBE LIGHT

RECOMMENDATIONS/FINDINGS

This being the second survey I have done in the past four yrs. I have found "CHIP AHOY" IN MUCH BETTER CONDITION THEN MY PREVIOUS SURVEY.THE SCOPE OF IMPROVEMENTS AND THE FUNDS THAT HAVE BEEN SPENT ON HER CARE AND MAINTENCE HAS BEEN INTENSE. SHE IS BETTER EQUIPTED THEN MOST VESSELS SAILING LOCALLY.I FEEL WITH HER MANY,MANY IMPROVEMENTS,IT IS EXTREMELY DIFFICULT TO FIND ANY RECOMMENDATIONS FOR HER OWNER. THE REPLACEMENT COST FOR "CHIP AHOY',NOW IS SOMEWHERE AROUND \$35,000. A NEW VESSEL OF HER SIZE FROM CATALINA WOULD BE CLOSE TO 35,000,PLUS ALL THE EQUIPMENT ABOARD HER,A NEW OWNER WOULD BE SPENDING CLOSE TO \$50,000.

I FEEL SHE IS VERY GOOD INSURANCE RISK AND SHOULD BE INSURED FOR \$25,000,TO PROTECT THE INVESTMENT THE OWNER HAS PUT FORTH.

RECOMMENDATIONS/FINDINGS WERE DISCUSSED WITH THE OWNER/MASTER OF THE VESSEL.THIS SURVEY HAS BEEN PREPARED AND SUBMITTED IN GOOD FAITH.IT IS UNDERSTOOD AND AGREED THAT THE SERVICES RENDERED BY CAPT. ALLAN JAY WALDMAN NAVTECH CERTIFIED MARINE SURVEYOR AS THE ATTENDING SURVEYOR WERE PREFORMED TO THE BEST OF MY ABILITIES.ANY REPORTS FURNISHED,EITHER ORAL OR IN WRITING,ARE ACCEPTED AS MY OPINION AND BEST JUDGEMENT.THEY ARE NOT IN ANYWAY INTENDED AS A REPRESENTATION OR WARRANTY AS TO THE CONDITION OF THE VESSEL OR ANY OF IT'S PARTS. IT IS FURTHER UNDERSTOOD AND AGREED THAT THIS SURVEYOR OF RECORD WILL NOT BE RESPONSIBLE FOR ANY LOSS OR DAMAGE DIRECT OR CONSEQUENCIAL,ARISING OUT OF THE CONDITION OF THE VESSEL,OR ANY ERROR OR OMISSION ON MY BEHALF AS SURVEYOR.

PAYMENT AND OR USE OF THIS SURVEY REPORT CONSTITUTUTES ACCEPTANCE OF THESE CONDITIONS.

Total charges;\$286.00

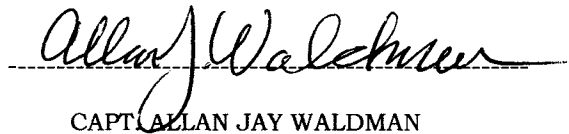

CAPT. ALLAN JAY WALDMAN

CERTIFIED MARINE SURVEYOR